

DA-PM8GD

DANTE POE PENDANT MOUNT SPEAKER

TECHNICAL DATA SHEET



PRODUCT SUMMARY

The AtlasIED DA-PM8GD is an 8" indoor pendant mount IP PoE amplified loudspeaker featuring Audinate's Dante digital audio transport platform. The DA-PM8GD supports a 8" efficient speaker design with a sensitivity of 98dB 1W/1m and a maximum output of 109dB.

AtlasIED Dante™ PoE speakers consist of a speaker, amplifier, control board, and a Dante™ interface. The DA-PM8GD amplifier can produce up to 15-watts RMS of power in single channel mode or up to 2 x 10-watts in dual channel mode with IEEE 802.3at compliant PoE+ switches and 10-watts single channel mode or 2 x 5-watts in dual channel mode with PoE power. Interconnection is via a top panel mounted female RJ-45 connector. All models are compatible with Audinate's Dante™ digital audio transport platform.

The DA-PM8GD features user configurable amplifier modes, Input EQ, Level Control, and Masking with room tuning EQ. All controls are done via the AtlasIED IP Discovery and Control software. Through this software, the active IP speaker can be discovered on the network with the ability to custom name each speaker with a location tag for system management. The AtlasIED control software features an audible ping-me locator making it convenient to physically locate the speaker. System tuning can be done on an individual speaker or by an assigned group.

The DA-PM8GD ships configured for single speaker use. It can also be configured to Dual mode to drive a second passive speaker of the same type like the PM8GD. When the DA-PM8GD amplifier is configured to Dual mode the amplifier power is split between the DA-PM8GD and passive speaker. The secondary speaker output shares the same factory EQ settings as the DA-PM8GD. Amplifier levels can be adjusted separately.

Attaching the DA-PM8GD to most overhead surfaces is a breeze. For open beam ceilings a 3 meter cable kit is included with a self-gripping ferrule system. If down pipe installation from hard ceiling material is required, any 3/4" ceiling fan installation kit may be utilized. These kits are readily available under the FANTEC brand from home improvement stores with various down pipe length options to provide installation ease regardless of ceiling material angle (Up to 45°).

Either installation solution is discreetly implemented via the PM series innovative top cover design. This cap includes a cable access plug that is easily removed for down pipe mounting. The cover also completely conceals the Ethernet cable terminations, and the suspension anchor points.

KEY FEATURES

- Extreme High Efficiency (98dB 1W/1m)
- 8" LF Transducer
- Mounting Options, Pole or Suspension Cable
- AES67 Compatible
- Integrated PoE Amplifier
- Secondary Amplifier Output for 8Ω Speaker
- Audinate Dante Digital Audio

Amplifier Configurations

- Single Channel Mode
- Dual Channel Mode

DSP & Control

- Individual Channel Level Control
- Dante Input Level, EQ & Limiter
- Sound Masking Generator, Level & EQ
- Find Me Locator Tone

Unique Features

- Create Custom Identification Names
- Group Control & Updating
- Status & Log Reporting

Network Features

- PoE or PoE+ Select or Auto Detect
- Dynamic or Static IP Address
- IEEE 802.3af Compliant
- Auto Registration with Dante Controller and AtlasIED Discovery Softwarebackground music.

DA-PM8GD

DANTE POE PENDANT MOUNT SPEAKER

TECHNICAL DATA SHEET



AUDIO SPECIFICATIONS / PERFORMANCE

SYSTEM	
Type	PoE / PoE+ Indoor 2' x 2' Suspended Ceiling Mount IP Speaker
Operation Mode	Self Powered
Indicators	Network Status
Operating Range (-10db)	70Hz - 15.5kHz
Frequency Response (+/- 5dB)	86Hz - 15.5kHz
Vertical Coverage	105° (800Hz - 4kHz)
Horizontal Coverage	105° (800Hz - 4kHz)
Directivity Factor (Q)	4.7 @ 2 kHz
Max SPL at 1m	106dB SPL Continuous / 109dB SPL Peak
Recommended Signal Processing	Built-In Processing
TRANSDUCERS	
Transducer Qty and Size	(1) 8" (203mm)
Voice Coil Size	1" (26mm)
Cone Material	Curvilinear, Treated Industrial Paper
Sensitivity	96dB Average
AMPLIFICATION	
Type	Two-Channel Class D Topology
Power Input	PoE (IEEE 802.3af) / PoE+ (IEEE 802.3at)
Single Ch Mode, Power Rating (RMS) PoE (IEEE 802.3AF)	10 Watts Max
Two Ch Mode, Power Rating (RMS) PoE (IEEE 802.3AF)	5 Watts Max, plus 5W @ 8 Ohm Paralleled Output
Single Ch Mode, Power Rating (RMS) PoE+ (IEEE 802.3AT)	15 Watts Max
Two Ch Mode, Power Rating (RMS) PoE+ (IEEE 802.3AT)	10 Watts Max, plus 10W @ 8 Ohm Paralleled Output
THD	<.02%
Cooling	Passive / Convection
AUDIO INPUTS AND OUTPUTS	
Input: Network Audio Type(s)	Audinate Dante
Input: Network Connectivity	RJ-45 Female
Output: Speaker Connectivity	Secondary Speaker Amplifier Output, Screw Terminal Block
SOFTWARE	
AtlasIED Discovery & Control Software	Discover, Status, Fault Report, User Setup & Control

(CONTINUED ON NEXT PAGE)

DA-PM8GD

DANTE POE PENDANT MOUNT SPEAKER

TECHNICAL DATA SHEET



SPECIFICATIONS / PERFORMANCE (CONTINUED)

USER CONTROL ELEMENTS	
Amplifier Operation Mode	Single Unit Mode or Two Channel Mode (Parallel Secondary Output)
Login	Username & Password
IP Mode	Static or DHCP
Product Locator	Audible Find Me Ping
Dante Input	Parametric EQ, 3 Filters, Hi-Pass Filter, Input Limiter Level
Amplifier Level	Ch 1 & CH 2
Masking	1/3 Octave EQ, Hi & Lo Pass Filter Level
File Export	Settings File, Device Profile
File Input	Settings File, Device Profile
NETWORK	
Ethernet	IEEE 802.3 10/100Base-T
PoE / PoE+	IEEE 802.3 AF/AT Compliant
PROTOCOLS	
IP Addressing	DHCP / Static
Auto-Registration	Dante Controller, AtlasIED Discovery & Control Software
Digital Audio	Audinate Dante Audio
Time	NTP
MECHANICAL	
Color	Black
Mounting / Rigging Provisions	Pendent Type - Cable Included, Down Pipe Optional
Ingress Protection	IP-30
Logo	Removable
Product Dimensions (HxD)	16.62" (422mm), Diameter - 12.25" (311mm)
Shipping Dimensions (HxWxD)	18.5" x 14.75" x 15" (470mm x 375mm x 381mm)
Net Weight	12.5 lbs (5.67kg)
Shipping Weight	15.5 lbs (7.03kg)
SAFETY RATINGS	
Safety Agency Ratings	ETL Listed 62368-1, CSA C22.2 #62368-1, IEC 62368-1 CB Scheme and FCC
WARRANTY COVERAGE	
Warranty Period	1 Year

NOTES:

1. Sensitivity: Half space pink noise measurement at 6 ft (1.8 m) at 20% power; extrapolated to 1 meter and an input of 2.83 volts RMS.
2. Watts: All wattage figures are calculated using the rated nominal impedance.
3. Frequency response and sensitivity are half-space measurements.

DA-PM8GD

DANTE POE PENDANT MOUNT SPEAKER

TECHNICAL DATA SHEET



Polars Are Normalized To Zero On Axis (-6dB)

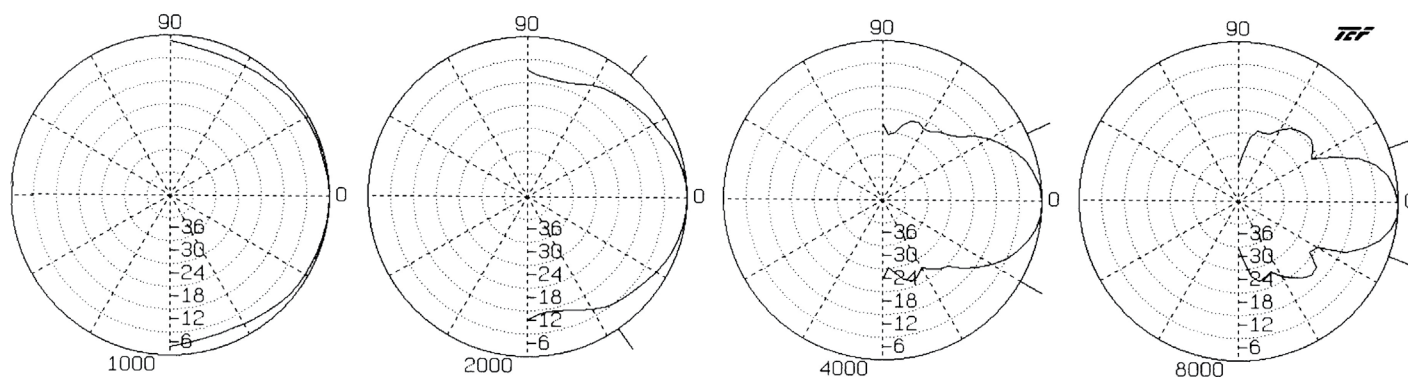

Frequency Response

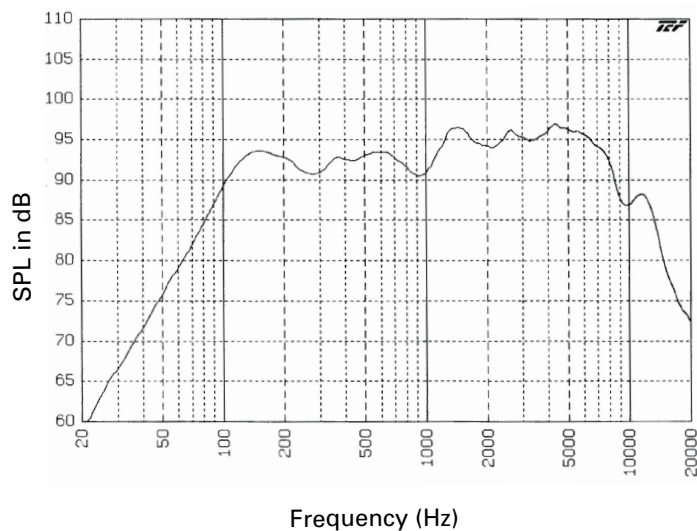

Impedance

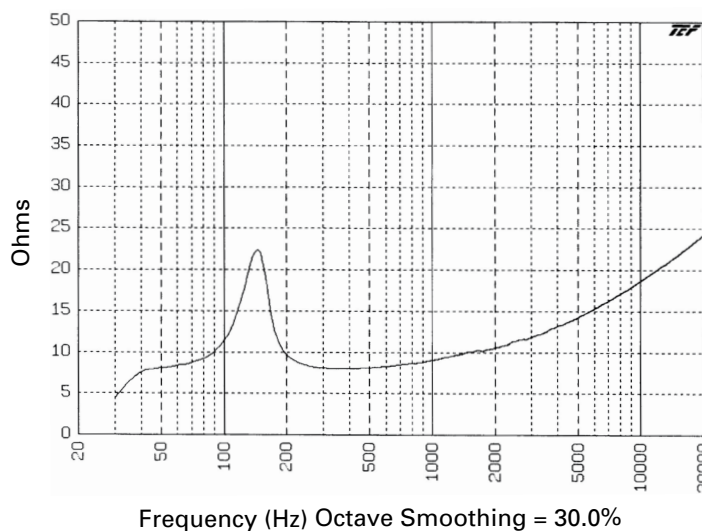

DA-PM8GD

DANTE POE PENDANT MOUNT SPEAKER

TECHNICAL DATA SHEET



DIMENSIONAL DRAWING

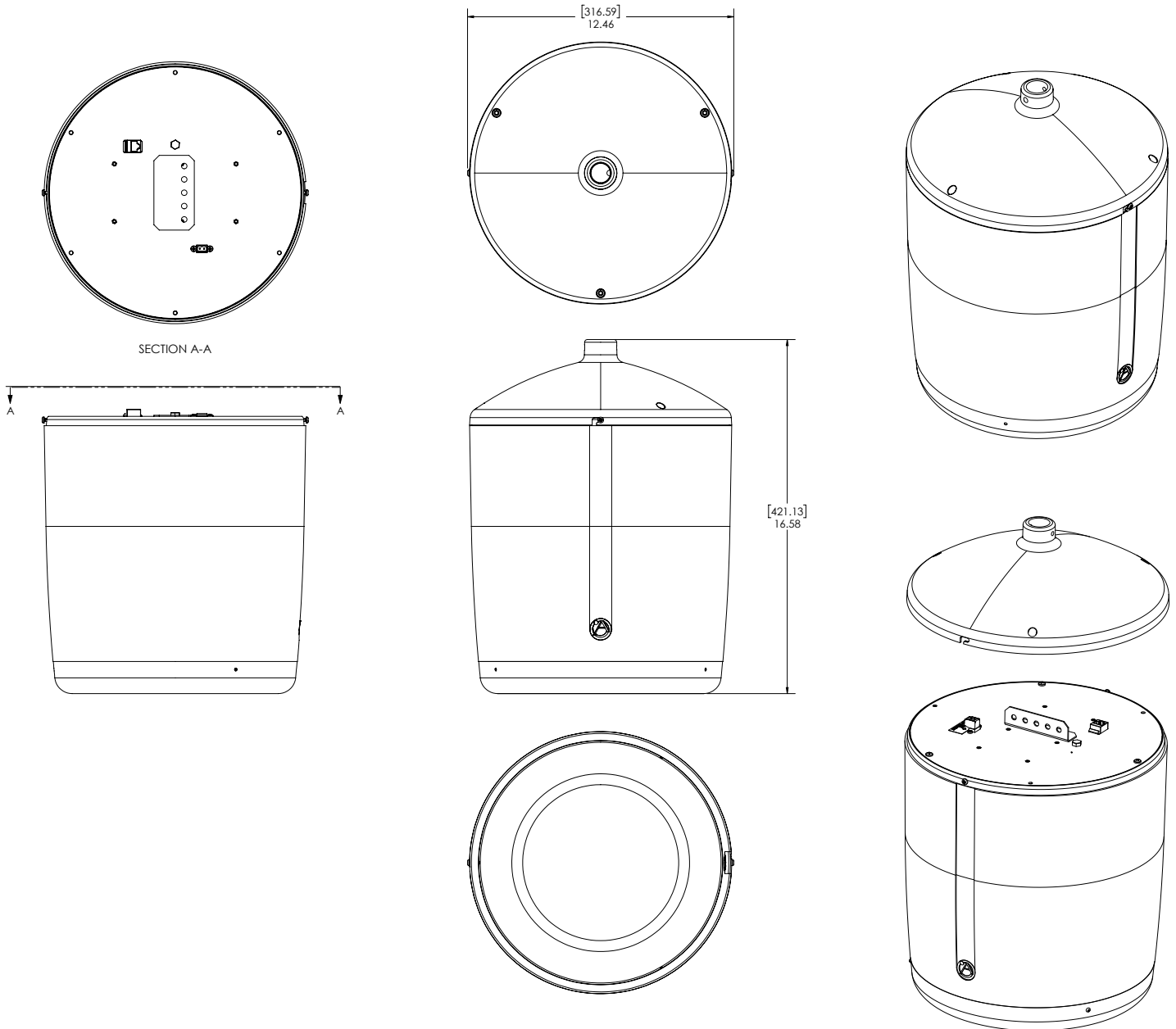

DA-PM8GD

DANTE POE PENDANT MOUNT SPEAKER

TECHNICAL DATA SHEET



ARCHITECT AND ENGINEER SPECS

The unit shall be AtlasIED model DA-PM8GD. The PoE+ indoor IP endpoint pendant mount speaker system shall include factory assembled speaker, IP addressable PCB amplifier / control in a tuned and ported bass reflex enclosure and form fit grille for conventional ceiling installation via cable or down tube mounting system.

The speaker shall be an 8" coaxial driver with low-frequency reproducer cone shall be a full 8" (203mm) in diameter and the high frequency reproducer cone shall be 3" (76mm) in diameter. The woofer shall have a 10oz. (260g) ceramic magnet; the tweeter shall have a 2.35oz. (67g) ceramic magnet. The two reproducer sections shall be coupled through a built-in crossover network.

The crossover frequency shall be at 2800Hz. The speaker dispersion shall be 105° and frequency response range shall be 70Hz - 15.5kHz, (±5dB).

Sensitivity shall be 98dB at 1 Watt / 1 meter. Voice coil impedance shall be 8Ω. Low frequency voice coil diameter shall be 1" (25mm) and operate in a magnet field of at least 10,600 gauss. The maximum depth of the loudspeaker shall not exceed 2⁷/₈" (73mm).

The amplifier / control board shall receive Audinate Dante Audio & control protocol that can be routed data on a standard Ethernet network. It shall include a single-channel Class D topology amplifier with Primary and Secondary outputs capable of producing 20-watts RMS when using an IEEE 802.3at compatible PoE+ switch. Interconnect shall be via female RJ-45 connector mounted to the PCB.

All control functionality shall be determined via software. It shall be compatible with AtlasIED software. The PoE+ indoor IP Dante endpoint pendant mount speaker system overall dimensions shall be 16.62" (422mm) diameter - 12.25" (311mm). Finish shall be black pedant style enclosure.